



**APPLICATION FOR A SPECIAL PERMIT TO OPERATE A TRUCK-TRACTOR - FOUR-AXLE  
SEMI-TRAILER COMBINATION WITH A SELF-STEERING AXLE TO TRANSPORT DRY BULK  
PRODUCTS AND NC-LL PRODUCTS**  
(Maximum GVW 54,000 kg – 55,500 kg)  
**NC-DB**

**SEND TO:**

Special Permit Office  
Transportation Policy Branch  
New Brunswick Department of Transportation  
P.O. Box 6000  
Fredericton, NB E3B 5H1

FAX: (506) 444-4488  
email:  
special.permits@gnb.ca

Permit fee: \$50/year

Registered owner: \_\_\_\_\_

Address: \_\_\_\_\_

City: \_\_\_\_\_ Prov.: \_\_\_\_\_ Postal code: \_\_\_\_\_

Phone no: (\_\_\_\_\_) \_\_\_\_\_ Fax: (\_\_\_\_\_) \_\_\_\_\_

**SEMI-TRAILER:**

► Make: \_\_\_\_\_ ► Year: \_\_\_\_\_

► Full serial number: \_\_\_\_\_

► Plate no: \_\_\_\_\_ ► Province of registration: \_\_\_\_\_

**Does the semi-trailer comply with all the following requirements?**      Yes       No

- Semi-trailer axle group 5, 6 and 7 must be a tridem group utilizing a full air suspension system.
- Axle 4 must be pneumatically tied into the tridem axle group 5, 6 and 7.
- For axle group 4, 5, 6, and 7, the load must be equalized between adjacent axles in the group to within 1000 kg.
- Axle 4 must be a self-steering axle.
- Axle 4 may be equipped with single tires with a minimum width of 365 mm, or dual tires.
- The self-steering axle may be liftable, but the controls, whether remote or manual, to raise or lower the self-steering axle must be located on the semi-trailer only, except for a semi-trailer designed to carry raw forest products where the controls can be in the cab.
- A semi-trailer may be equipped with an automatic control, which raises the self-steering axle when the vehicle is reversing.
- The tractor may have a manual controls to allow the driver to raise the self-steering axle to provide emergency drive axle traction but only if the controls do not activate unless the emergency 4-way flashers are activated and the controls must include a device which prevents the raising the axle at any speed in excess of 60 km/hr.
- The quad-axle semi-trailer must be equipped with a device that accurately displays the total weight on the semi-trailer axles in kilograms, or with a device and a table or chart from the combined use of which the total weight on the semi-trailer axles in kilograms may be readily and accurately obtained.

Truck and semi trailer combinations must comply with either diagram #1 or #2 below.

Please select the diagram that matches your vehicle configurations:  
(One diagram only per application)

Vehicle #1 – GVW = 55,500 kg maximum\* Axle 4: single tires  dual tires

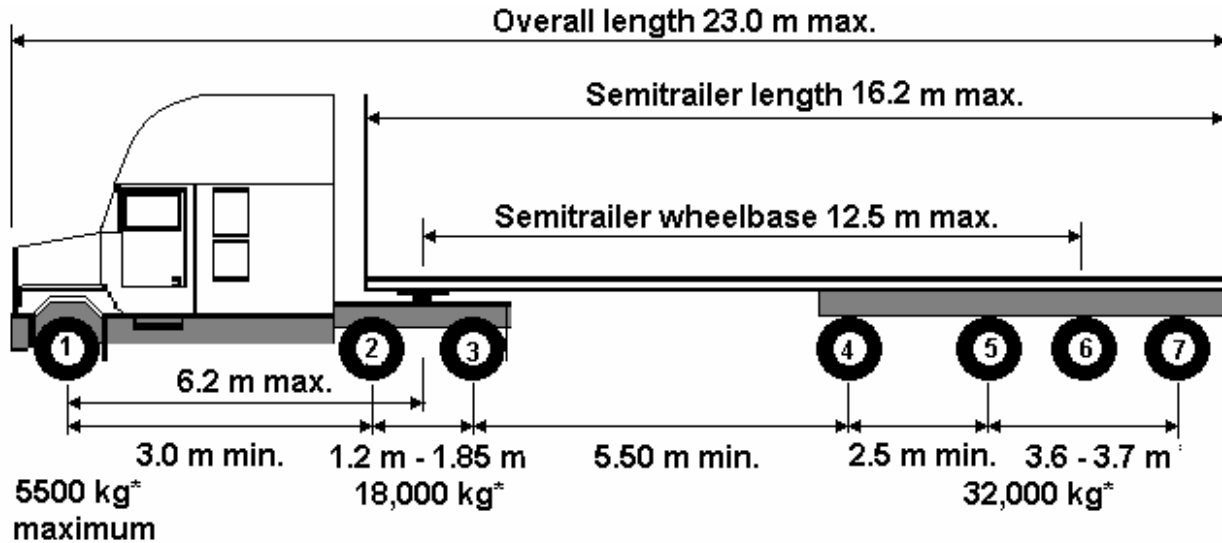

**\* NOTE: No additional weight (mass) will be permitted beyond these values.**

Vehicle #2 – GVW = 54,000 kg maximum\* Axle 4: single tires  dual tires

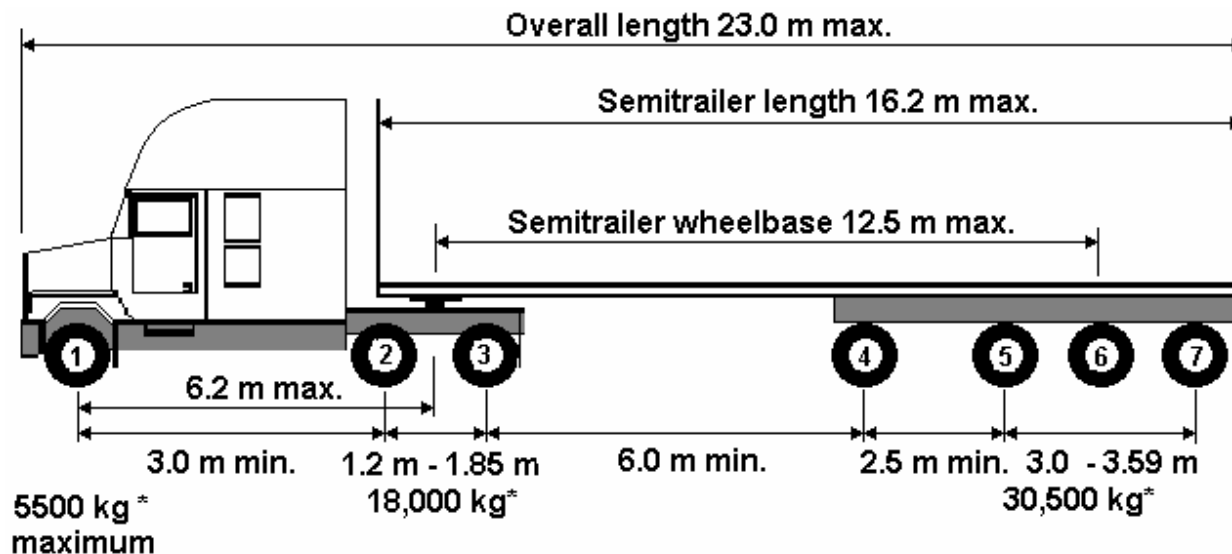

**\* NOTE: No additional weight (mass) will be permitted beyond these values.**

**Note: For the above diagrams #1 and #2:**

- All other vehicle dimensions must comply with Regulation 2001-67.
- All axles except steering axle and axle 4 must be equipped with dual tires.
- All axles on trailer must utilize a full air suspension that equalizes the load between the axles to within 1000 kg.
- All four axles of the semi-trailer must be deployed when trailer is loaded and operating.

Dry bulk is defined as unpackaged free flowing dry solids that are loaded without being boxed bagged or hand stowed. Examples of dry bulk include but are not limited to: sand, gravel, grain, potash, salt, sugar, aggregate, coal, grain, wood chips, cement powder, chemicals (fertilizer, plastic granules and pellets, resin powder), dry edibles (alfalfa pellets, citrus pellets, livestock feed, flour, meal, seeds, starches) and bulk mine (mineral ore, salt).

NC-LL products include round wood and logs loaded longitudinally, wood chips and hog fuel.

Vehicles must be registered for the weights allowed on the permit.

<b>Payment details (do not send cash by mail):</b>	
Cash <input type="checkbox"/> Cheque or Money order <input type="checkbox"/> VISA <input type="checkbox"/> Mastercard <input type="checkbox"/>	
Credit card number:	Expiry date (mm/yy):

<b>Send permit to: Company (provide fax number if different from above) <input type="checkbox"/></b>
Scale <input type="checkbox"/> District <input type="checkbox"/> SNB Office <input type="checkbox"/> Location:

I hereby apply for a special permit to operate a truck-tractor and a four-axle semi-trailer, as described above, for travel in the Province of New Brunswick, transporting ONLY dry bulk products.

I understand that the permit, if it is issued, shall expire one year from the date of issue. This vehicle may be inspected during the term of said permit, to evaluate its safety and weight distribution characteristics. I further understand that an unsatisfactory carrier safety rating may be grounds for not issuing a permit, or subsequent cancellation of a permit.

I acknowledge that I have read and understood the information and requirements contained in this application and I certify that the information provided on this application is true and correct.

Name (Print): \_\_\_\_\_

Signature: \_\_\_\_\_ Date: \_\_\_\_\_